

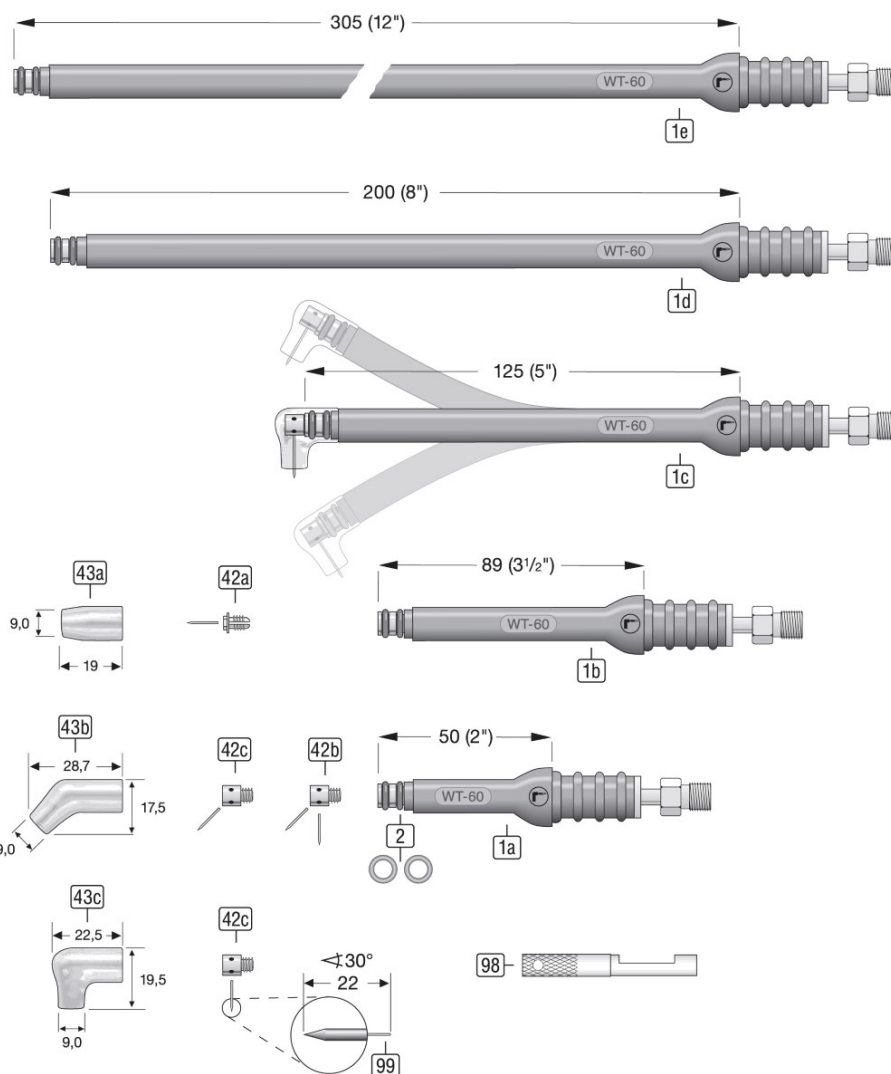

Data Sheet

WT60S/ WT60/ WT60F/ WT60M/ WT60L

WeldTec



00.DBL-8560106S-106L

01/2022

TIG Torch WT60S,WT60,WT60F,WT60M,WT60L**Wearing parts**

| # | Item description | Part no |
|-----|---|----------------|
| 42a | Chuck Ø0,5mm 0° [125C20] WT-60/125 | 8512125C020 |
| | Chuck Ø1,0mm 0° [125C40] WT-60/125 | 8512125C040 |
| | Chuck Ø1,6mm 0° [125C116] WT-60/125 | 8512125C116 |
| | Chuck Ø2,4mm 0° [125C332] WT-60/125 | 8512125C332 |
| 42b | Chuck Ø1,0mm 45/90° [125C40C] WT-60/125 | 8512125C040C |
| | Chuck Ø1,6mm 45/90° [125C116C] WT-60/125 | 8512125C116C |
| 42c | Chuck Ø2,4mm 45° [125C332-45]WT-60/125 | 8512125C332-45 |
| | Chuck Ø2,4mm 90° [125C332-90]WT-60/125 | 8512125C332-90 |
| 43a | Glass Nozzle 0° Quartz [125N180Q] WT-60/125 | 85912N180Q |
| 43b | Glass Nozzle 45° Quarz [125N45Q] WT-60/125 | 85912N45Q |
| 43c | Glass Nozzle 90° Quarz [125N90Q] WT-60/125 | 85912N90Q |
| 98 | Wrench [53N20] WT-24/60/125 | 85521002 |
| 99 | Tungsten Electrode Ø1,6mm L=22mm WC20 grey 2% Ceroxid sharpened | 85831600-022S |

Components

| # | Item description | Part no |
|----|-------------------------------|---------------|
| 1a | Torch Body WT-60S air cooled | 8560106S |
| 1b | Torch Body WT-60 air cooled | 85601060 |
| 1c | Torch Body WT-60F air cooled | 85601062 |
| 1d | Torch Body WT-60M air cooled | 8560106M |
| 1e | Torch Body WT-60L air cooled | 8560106L |
| 2 | O-ring [98W77] WT-9/20/60/125 | 85509-98W77-W |