

Datenblatt

Brenner M 150 EP

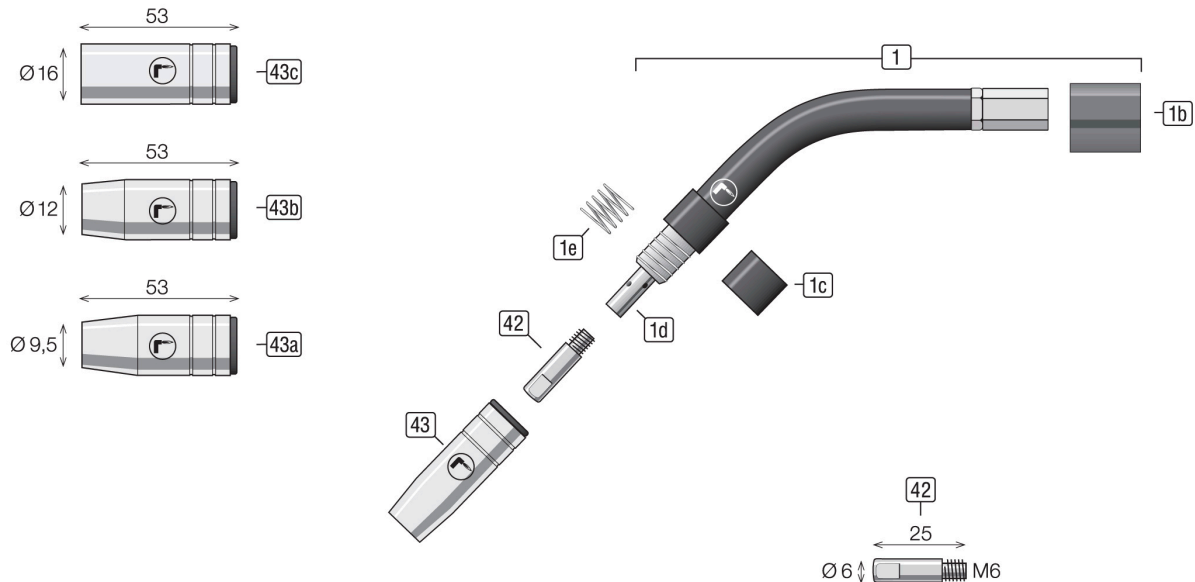

00.DBL-MBH150

04-2018

Ersatzteile

Pos.	Artikelbezeichnung	Artikel
1	Brennerkörper MEP-150 luftgekühlt	MBH150
1b	Zwischenkörper Kunststoff MIG/MAG Brenner luftgekühlt	MBH-ZK
1c	Isolator für MBH150 Düsen Seite	MI150
1d	Düsenstock M6 L=42mm MEP-150	MDSM8L-M6X42
1e	Haltefeder MEP-150	MHF150

Ausrüstungsteile

Pos.	Artikelbezeichnung	Artikel
42	Stromdüse E-Cu M6 L=25mm Ø0,6mm MEP-150	MSDECUM6X25-06
	Stromdüse E-Cu M6 L=25mm Ø0,8mm MEP-150	MSDECUM6X25-08
	Stromdüse E-Cu M6 L=25mm Ø1,0mm MEP-150	MSDECUM6X25-10
	Stromdüse E-Cu M6 L=25mm Ø0,8mm Alu MEP-150	MSDECUM6X25-08A
	Stromdüse E-Cu M6 L=25mm Ø1,0mm Alu MEP-150	MSDECUM6X25-10A
	Stromdüse E-Cu Ni M6 L=25mm Ø0,8mm MEP-150	MSDECNM6X25-08
	Stromdüse E-Cu Ni M6 L=25mm Ø1,0mm MEP-150	MSDECNM6X25-10
	Stromdüse CuCrZr M6 L=25mm Ø0,8mm MEP-150	MSDCCZM6X25-08
	Stromdüse CuCrZr M6 L=25mm Ø1,0mm MEP-150	MSDCCZM6X25-10
43a	Gasdüse NW9,5 L=53mm stark konisch MEP-150	MGDK150-095
43b	Gasdüse NW12,0 L=53mm konisch MEP-150	MGDK150-120
43c	Gasdüse NW16,0 L=53mm zylindrisch MEP-150	MGDZ150-160
	Punktgasdüse NW16,0 L=60mm MEP-150	MGDP150-160